

WESTFALL PLACE

PRIMARY PLAT

SECTION 3-T19N-R2W & SECTION 34-T20N-R2W
SUGAR CREEK TOWNSHIP
BOONE COUNTY, THORNTOWN, INDIANA
Zoning: PUD-01-2022 (Ordinance No. 2023-05)



Innovative
ENGINEERING & CONSULTING
Whitestown, IN 46075
www.innovativeeci.com

REVISIONS:

NO.	DESCRIPTION	DATE
1	REVISION PER IAC COMMENTS - 8/28/23	

PREPARED FOR:
Arbor Homes
9225 Harrison Park Ct
Indianapolis, Indiana 46216

THORNTOWN RESIDENTIAL
Westfall Place
8401 West State Road 47, Thorntown, Indiana 46071
COVER SHEET

DATE: _____
DRAWN BY: _____
ISSUED: _____
CHECKED BY: _____
JOB NUMBER: _____
22101

PRELIMINARY
PENDING
AGENCY
APPROVAL

SHEET #
P100

Sheet No.	Description
P100	Cover Sheet
P101a	Overall Plan
P101b	Block Exhibit Dimension Plan
P101-P104	Primary Plat
P105-P108	Development Plan

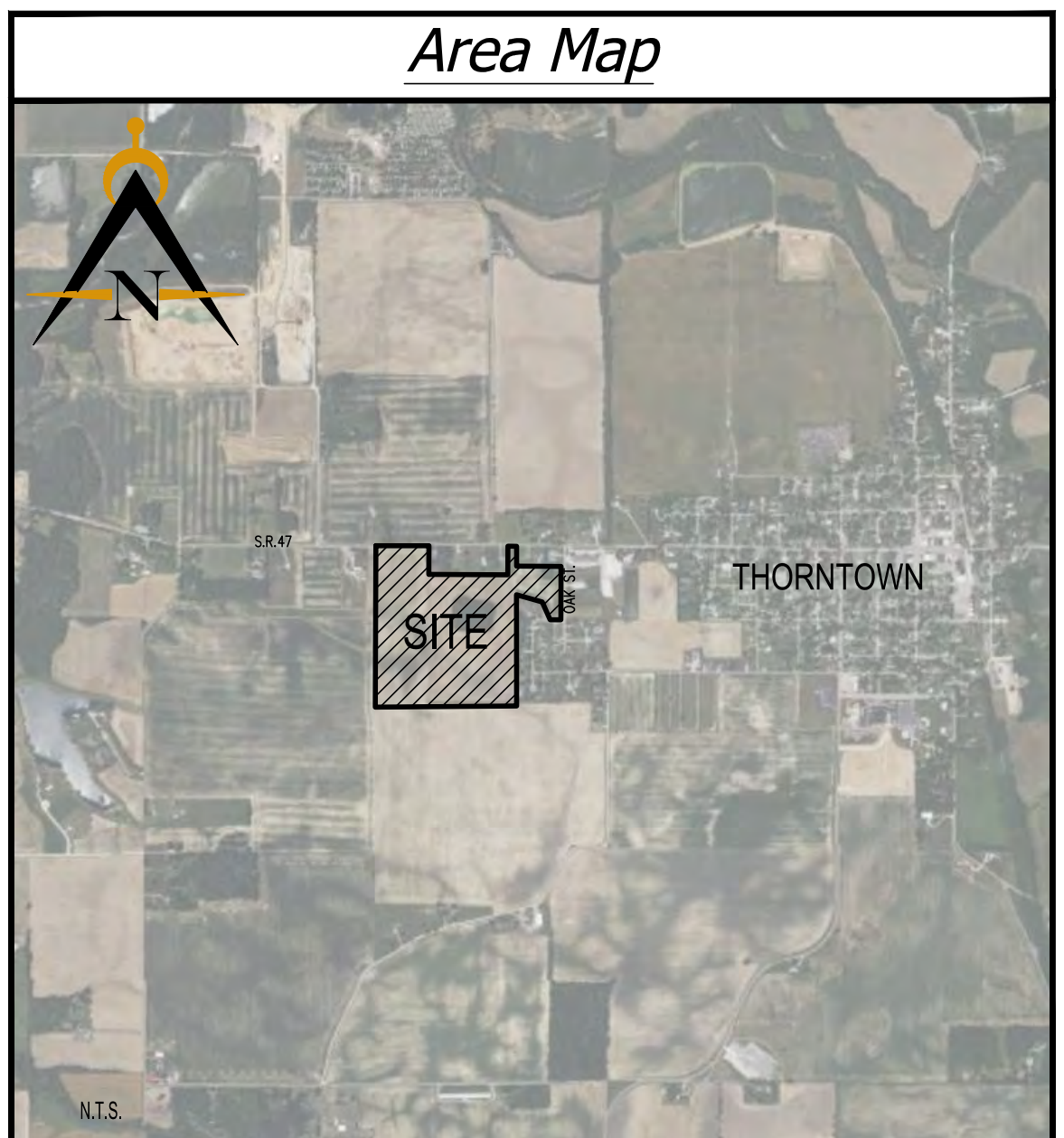

Project Map
SCALE: 1"=200'

Number of Lots: 163
Total Acreage: 66.5 ac.
Density: 2.45 Lots/Acre
Open Space Area: 25.9 Acres

NOTE: PROPOSED HOMES IN THIS RESIDENTIAL DEVELOPMENT ARE SLAB ON GRADE. NO CRAWL SPACES. BUT THE OPTION TO ALLOW BASEMENTS ON SOME LOTS WILL BE GRANTED. ON THOSE LOTS A SUBSURFACE DRAIN LATERAL WILL BE PROVIDED TO THE LOT. ON LOTS WHERE THERE IS NO SUBSURFACE DRAIN LATERAL PROVIDED, THOSE LOTS WILL BE CLEARLY DENOTED ON THE FINAL PLAT AND CONSTRUCTION PLANS AS "NON-BASEMENT" LOTS AND NO BASEMENTS WILL BE ALLOWED ON THOSE LOTS.

REVISIONS:
1) REVISED PER IAC COMMENTS - 8/28/23

Arbor Homes
9225 Harrison Park CT
Indianapolis, Indiana 46216

Prepared For:
**Thorntown Residential
Westfall Place**
8401 West State Road 47, Thorntown, Indiana 46071

**PRELIMINARY
PENDING
AGENCY
APPROVAL**

DATE: 08/30/23
ISSUED: kkw
CHECKED BY:

JOB NUMBER:
22101

SHEET #
P101a

File Path Name: J:\2022\22101 - Thorntown Due Diligence\Drawings\Primary Plat.dwg - Date: Aug 31, 2023 - 3:49pm

LEGEND

- Existing Storm Sewer
- New Storm Sewer
- Existing Sanitary Sewer
- New Sanitary Sewer
- Denotes Building Pad
- 8" WTR New Water Main
- New Fire Hydrant
- New Water Valve
- Existing Gas Main
- Existing Telephone
- Existing Water Main
- Existing Flowline
- Existing Overhead Utilities
- 8" WTR Existing Water Main
- Existing Fire Hydrant
- Existing Water Valve
- Utility & Drainage Esmt.
- Building Setback Line
- ▲ Traditional Lots 55'x130' (85)
- Traditional Wide Lots 61'x130' (64)
- Lots Variable Width & Depth (14)

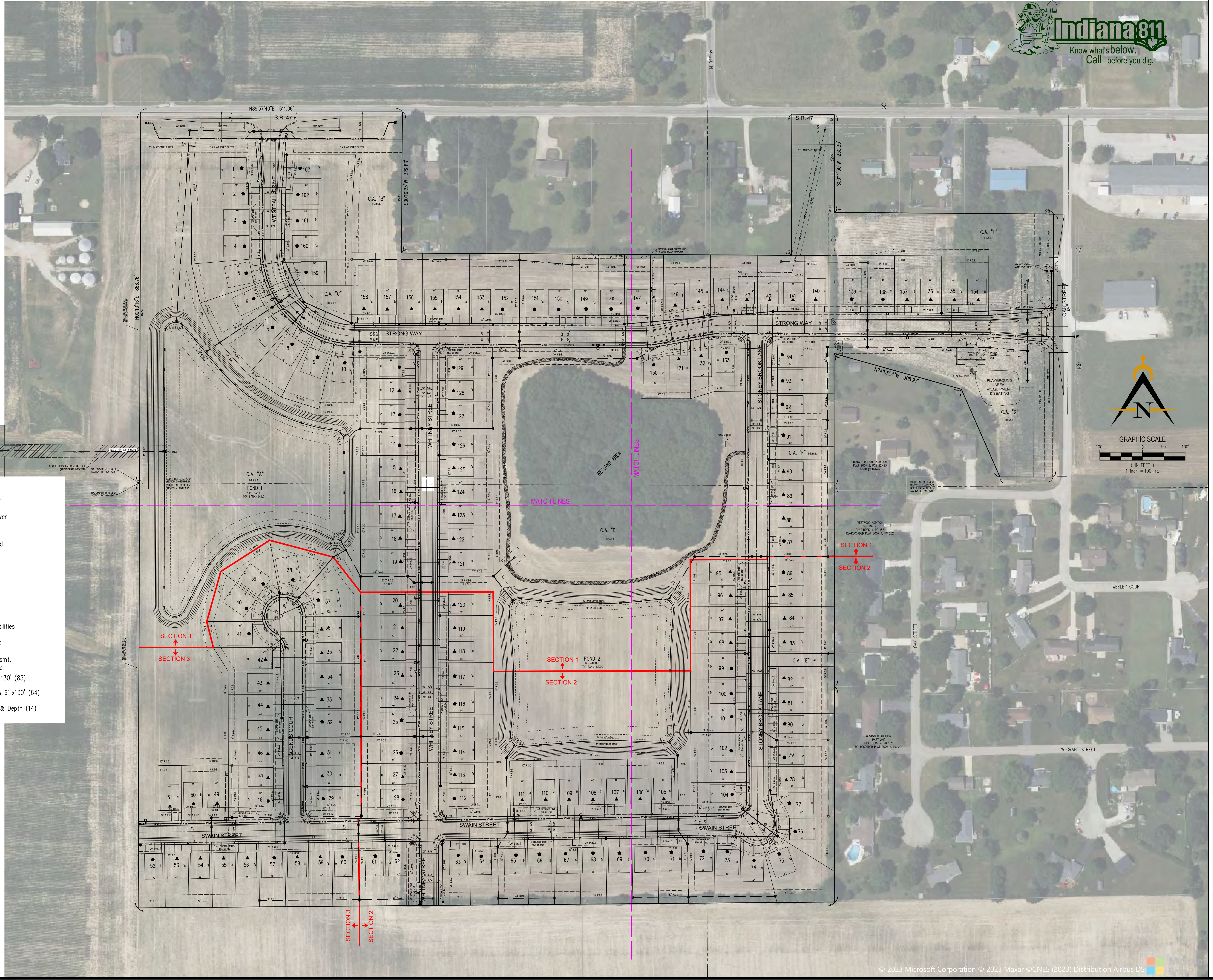

REVISIONS:

1.	REVISED PER IAC COMMENTS - 8/28/23
----	------------------------------------

PREPARED FOR:

Arbor Homes
9225 Harrison Park CT
Indianapolis, Indiana 46216

THORNTOWN RESIDENTIAL
WESTFALL PLACE

8401 West State Road 47, Thornton, Indiana 46071

BLOCK EXHIBIT DIMENSION PLAN

**PRELIMINARY
PENDING
AGENCY
APPROVAL**

DATE:	08/30/23	DRAWN BY:	WCS
ISSUED:		CHECKED BY:	RGG
JOB NUMBER:	22101		
SHEET #	P101b		

File Path Name: C:\Temp\MapPublish_5964\p101b Primary Plot Block Exhibit.dwg -- Date: Aug 31, 2023 -- 3:52pm

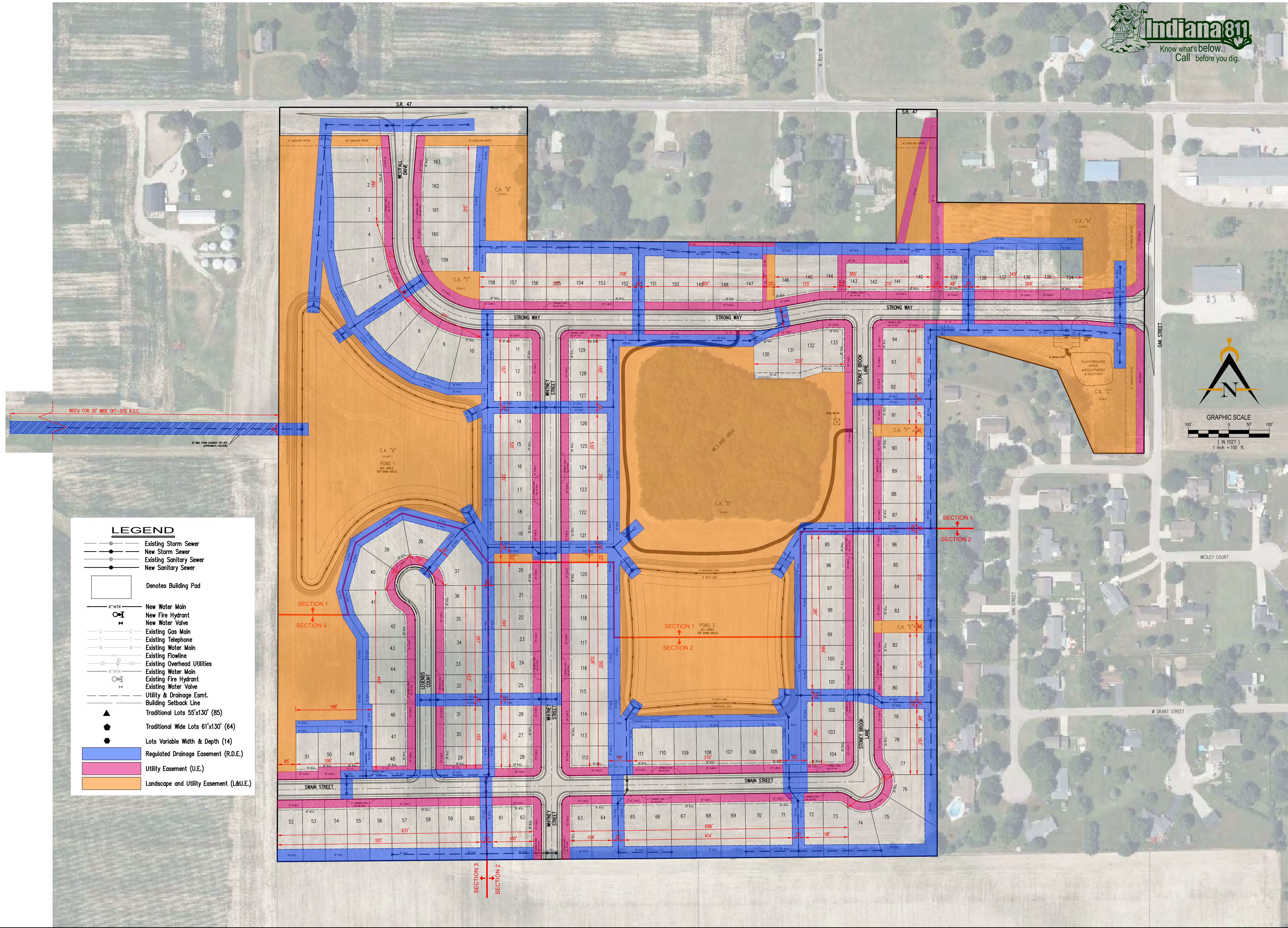

LEGEND

- Existing Storm Sewer
- New Storm Sewer
- Existing Sanitary Sewer
- New Sanitary Sewer
- Denotes Building Pad
- 8" WTR New Water Main
- New Fire Hydrant
- New Water Valve
- Existing Gas Main
- Existing Telephone
- Existing Water Main
- Existing Flowline
- Existing Overhead Utilities
- Existing Water Main
- Existing Fire Hydrant
- Existing Water Valve
- Utility & Drainage Easmt.
- Building Setback Line
- ▲ Traditional Lots 55'x130' (85)
- Traditional Wide Lots 61'x130' (64)
- Lots Variable Width & Depth (14)
- Regulated Drainage Easement (R.D.E.)
- Utility Easement (U.E.)
- Landscape and Utility Easement (L&U.E.)



Developer:
 Arbor Homes
 9225 Harrison Park Ct.
 Indianapolis, IN 46216
 317-827-6643

Engineer/Surveyor:
 Innovative Engineering & Consulting, Inc.
 3961 Perry Boulevard
 Whitestown, IN 46075
 317-769-2916

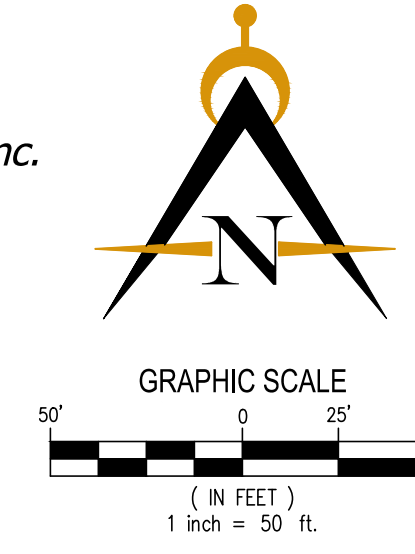

LEGEND

- B.S.L. - BUILDING SETBACK LINE
- D.&U.E. - DRAINAGE & UTILITY EASEMENT
- D.E. - DRAINAGE EASEMENT
- R.D.E. - REGULATED DRAINAGE EASEMENT
- U.E. - UTILITY EASEMENT
- W.E. - WATER EASEMENT
- L.E. - LANDSCAPE EASEMENT
- C.A. - COMMON AREA
- ▲ - TRADITIONAL LOTS 55'x130' (85)
- - TRADITIONAL WIDE LOTS 61'x130' (64)
- - LOTS VARIABLE WIDTH & DEPTH (14)

NOTE:
 ALL STREET INTERSECTION PROPERTY LINE CORNERS ARE
 ROUNDED BY AN ARC WITH A 20' RADIUS.
 CURVE TABLE IS ON SHEET P104.

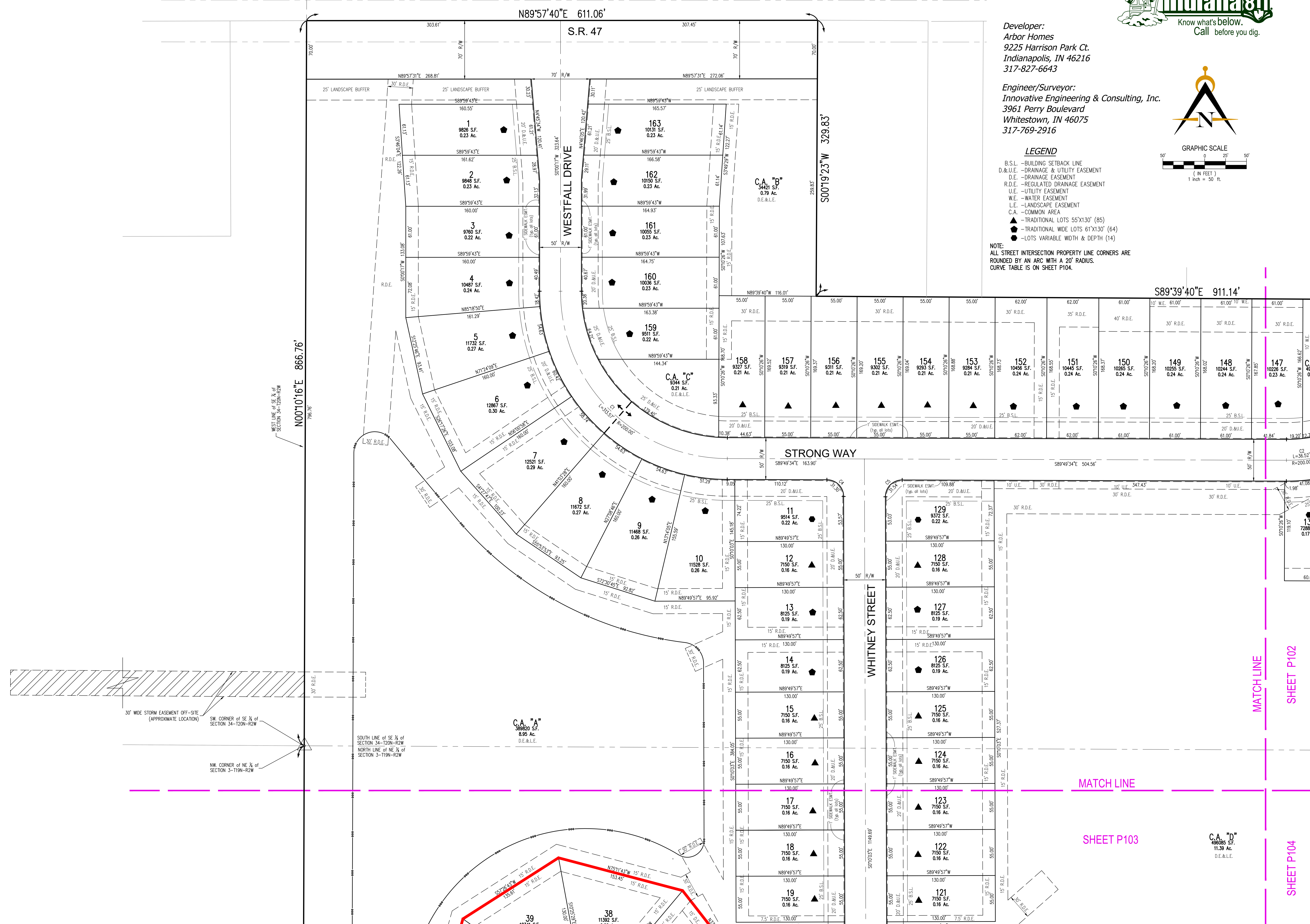

Innovative
 ENGINEERING & CONSULTING

Whitestown, IN 46075
 3961 Perry Boulevard
 Ph: 317-769-2916
 www.innovativeci.com

REVISIONS:

1	REVISED PER IAC COMMENTS - 8/28/23
---	------------------------------------

Arbor Homes
 9225 Harrison Park Ct
 Indianapolis, Indiana 46216

Thorntown Residential
 Westfall Place
 8401 West State Road 47, Thorntown, Indiana 46071
 PRIMARY PLAT

**PRELIMINARY
 PENDING
 AGENCY
 APPROVAL**

DATE: 08/30/23
 DRAWN BY: kwk
 ISSUED: CHECKED BY:
 JOB NUMBER: 22101
 SHEET # P101

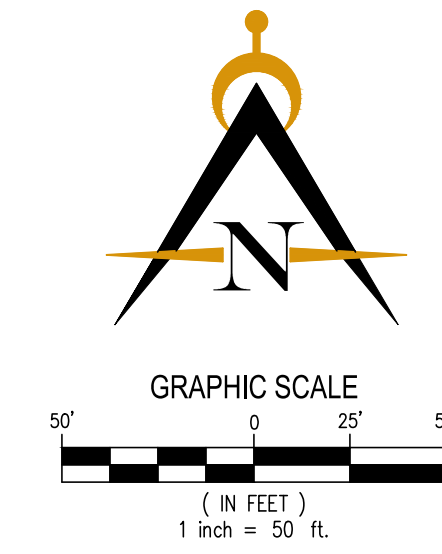

Developer:
Arbor Homes
9225 Harrison Park Ct.
Indianapolis, IN 46216
317-827-6643

Engineer/Surveyor:
Innovative Engineering & Consulting, Inc.
3961 Perry Boulevard
Whitestown, IN 46075
317-769-2916

LEGEND

- B.S.L. - BUILDING SETBACK LINE
- D.&U.E. - DRAINAGE & UTILITY EASEMENT
- D.E. - DRAINAGE EASEMENT
- R.D.E. - REGULATED DRAINAGE EASEMENT
- U.E. - UTILITY EASEMENT
- W.E. - WATER EASEMENT
- L.E. - LANDSCAPE EASEMENT
- C.A. - COMMON AREA
- ▲ - TRADITIONAL LOTS 55'x130' (85)
- ▲ - TRADITIONAL WIDE LOTS 61'x130' (64)
- - LOTS VARIABLE WIDTH & DEPTH (14)

NOTE:
ALL STREET INTERSECTION PROPERTY LINE CORNERS ARE
ROUNDED BY AN ARC WITH A 20' RADIUS.
CURVE TABLE IS ON SHEET P104.



REVISIONS:

Arbor Homes
9225 Harrison Park Ct.
Indianapolis, Indiana 46216

PREPARED FOR:
Thorntown Residential
Westfall Place
8401 West State Road 47, Thorntown, Indiana 46071
PRIMARY PLAT

PRELIMINARY
PENDING
AGENCY
APPROVAL

DATE: 08/30/23
DRAWN BY: kwk
ISSUED: CHECKED BY:
JOB NUMBER: 22101
SHEET # P102

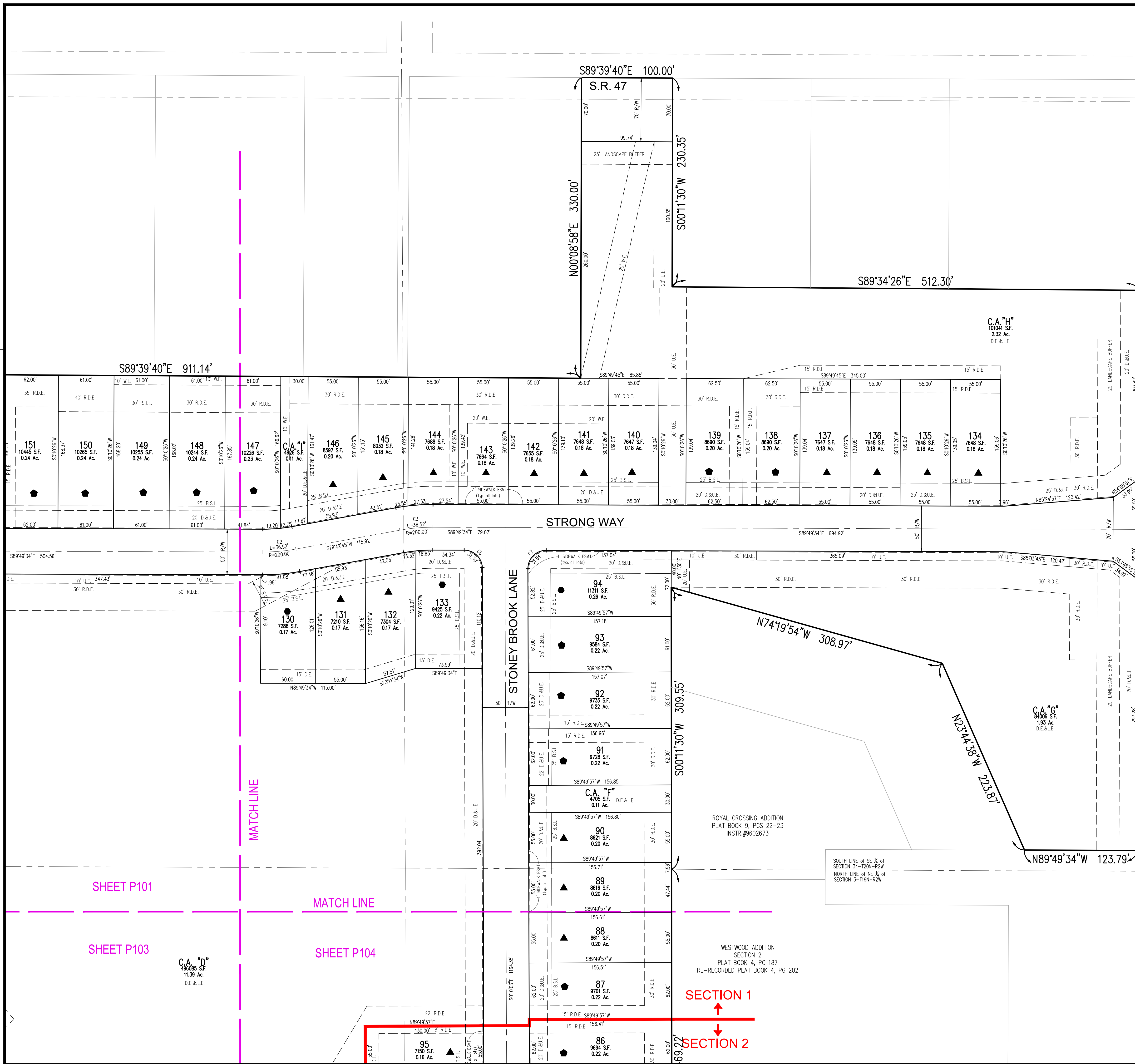

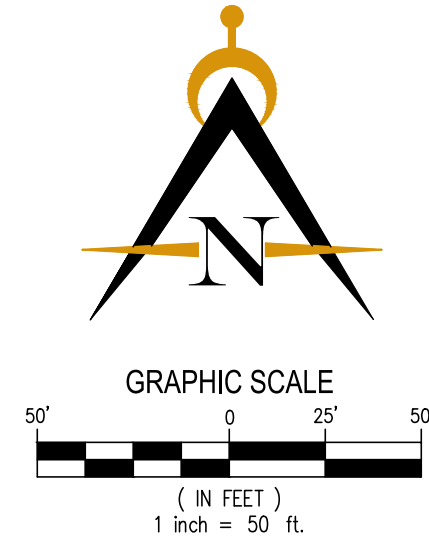

Developer:
Arbor Homes
9225 Harrison Park Ct.
Indianapolis, IN 46216
317-827-6643

Engineer/Surveyor:
Innovative Engineering & Consulting, Inc.
3961 Perry Boulevard
Whitestown, IN 46075
317-769-2916

LEGEND

- B.S.L. - BUILDING SETBACK LINE
- D.&U.E. - DRAINAGE & UTILITY EASEMENT
- D.E. - DRAINAGE EASEMENT
- R.D.E. - REGULATED DRAINAGE EASEMENT
- U.E. - UTILITY EASEMENT
- W.E. - WATER EASEMENT
- L.E. - LANDSCAPE EASEMENT
- C.A. - COMMON AREA
- ▲ - TRADITIONAL LOTS 55'x130' (85)
- - TRADITIONAL WIDE LOTS 61'x130' (64)
- - LOTS VARIABLE WIDTH & DEPTH (14)

NOTE:
ALL STREET INTERSECTION PROPERTY LINE CORNERS ARE ROUNDED BY AN ARC WITH A 20' RADIUS. CURVE TABLE IS ON SHEET P104.

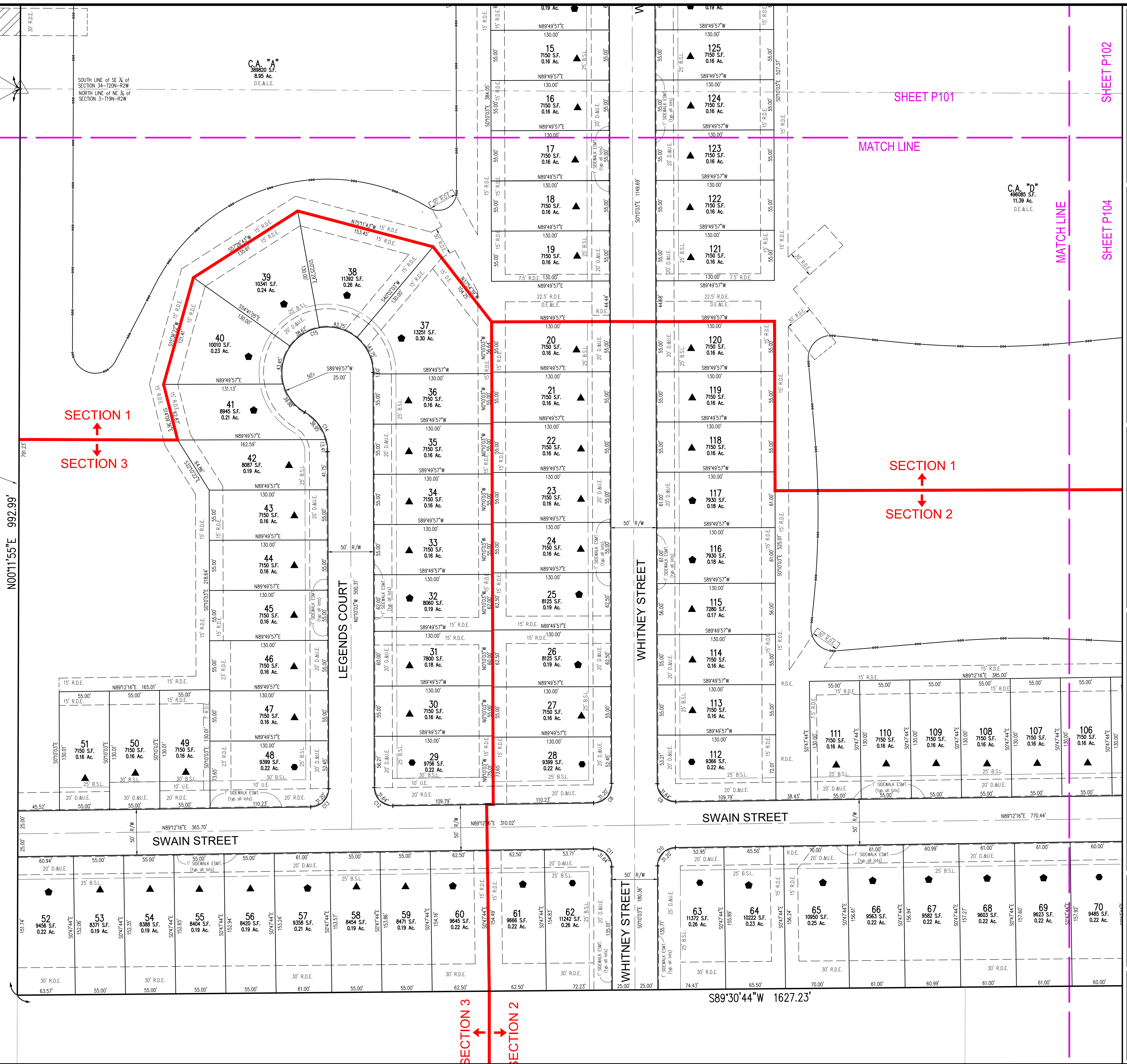

Innovative
ENGINEERING & CONSULTING

Whitestown, IN 46075
3961 Perry Boulevard
Ph. 317-769-2916
www.innovativeci.com

REVISIONS:

1	REVISED PER IAC COMMENTS - 8/28/23
---	------------------------------------

Prepared For:
Arbor Homes
9225 Harrison Park Ct.
Indianapolis, Indiana 46216

Thorntown Residential Westfall Place
8401 West State Road 47, Thorntown, Indiana 46071
PRIMARY PLAT

PRELIMINARY PENDING AGENCY APPROVAL

DATE: 08/30/23
DRAWN BY: kwk
ISSUED: CHECKED BY:
JOB NUMBER: 22101
SHEET # P103



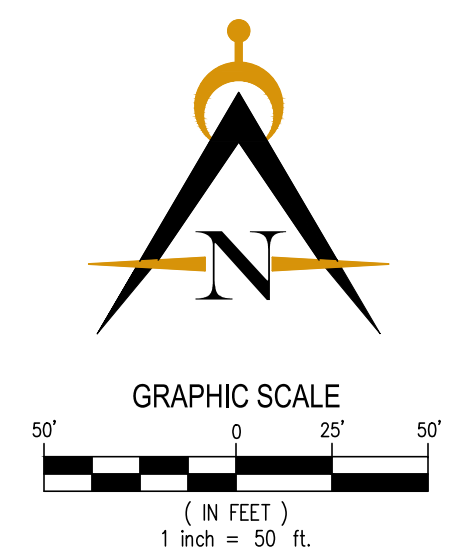
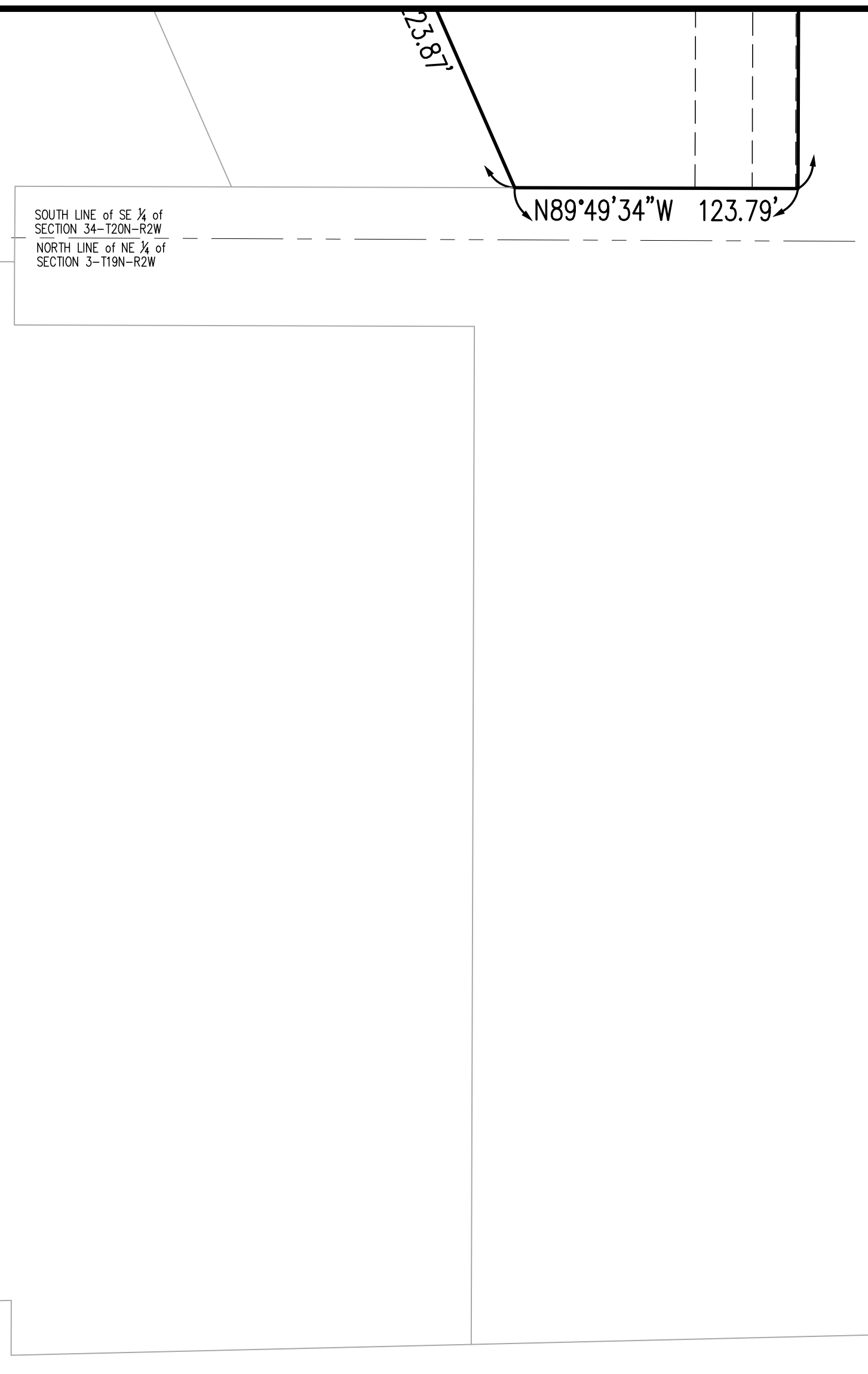
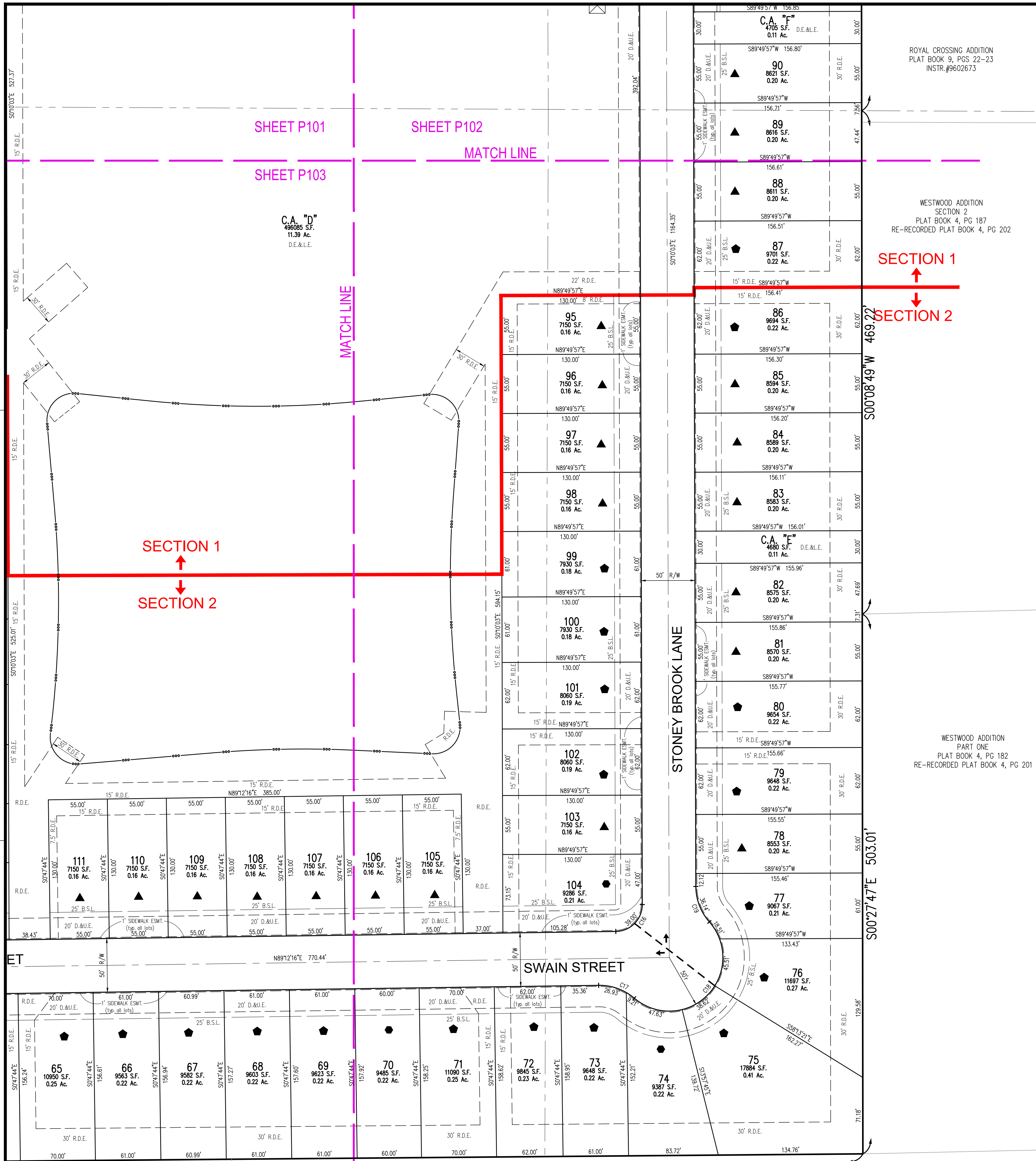

Developer:
Arbor Homes
 9225 Harrison Park Ct.
 Indianapolis, IN 46216
 317-827-6643

Engineer/Surveyor:
Innovative Engineering & Consulting, Inc.
 3961 Perry Boulevard
 Whitestown, IN 46075
 317-769-2916

LEGEND

- B.S.L. - BUILDING SETBACK LINE
 - D.&U.E. - DRAINAGE & UTILITY EASEMENT
 - D.E. - DRAINAGE EASEMENT
 - R.D.E. - REGULATED DRAINAGE EASEMENT
 - U.E. - UTILITY EASEMENT
 - W.E. - WATER EASEMENT
 - L.E. - LANDSCAPE EASEMENT
 - C.A. - COMMON AREA
 - ▲ - TRADITIONAL LOTS 55'X130' (85)
 - - TRADITIONAL WIDE LOTS 61'X130' (64)
 - - LOTS VARIABLE WIDTH & DEPTH (14)
- NOTE:
 ALL STREET INTERSECTION PROPERTY LINE CORNERS ARE ROUNDED BY AN ARC WITH A 20' RADIUS. CURVE TABLE IS ON SHEET P104.

Curve #	Length	Radius	Delta	Chord Direction	Chord Length	Tangent
C1	313.57'	200.00'	89° 49' 50"	S44° 54' 39"E	282.42'	199.41'
C2	36.52'	200.00'	10° 27' 41"	N84° 56' 36"E	36.47'	18.31'
C3	36.52'	200.00'	10° 27' 41"	S84° 56' 36"W	36.47'	18.31'
C4	31.30'	20.00'	89° 39' 31"	N44° 59' 48"W	28.20'	19.88'
C5	31.54'	20.00'	90° 20' 29"	S45° 00' 12"W	28.37'	20.12'
C6	31.30'	20.00'	89° 39' 31"	N44° 59' 48"W	28.20'	19.88'
C7	31.54'	20.00'	90° 20' 29"	S45° 00' 12"W	28.37'	20.12'
C8	31.20'	20.00'	89° 22' 19"	N44° 31' 07"E	28.13'	19.78'
C9	31.64'	20.00'	90° 37' 41"	S45° 28' 53"E	28.44'	20.22'
C10	31.20'	20.00'	89° 22' 19"	S44° 31' 07"W	28.13'	19.78'
C11	31.64'	20.00'	90° 37' 41"	N45° 28' 53"W	28.44'	20.22'
C12	31.64'	20.00'	90° 37' 41"	S45° 28' 53"E	28.44'	20.22'
C13	31.20'	20.00'	89° 22' 19"	N44° 31' 07"E	28.13'	19.78'
C14	52.36'	50.00'	60° 00' 00"	N30° 10' 03"W	50.00'	28.87'
C15	209.44'	50.00'	240° 00' 00"	S59° 49' 57"W	86.60'	86.60'
C16	39.00'	25.00'	89° 22' 19"	N44° 31' 07"E	35.16'	24.73'
C17	36.14'	50.00'	41° 24' 35"	N70° 05' 26"W	35.36'	18.90'
C18	150.27'	50.00'	172° 11' 28"	N44° 31' 07"E	99.77'	732.60'
C19	36.14'	50.00'	41° 24' 35"	S20° 52' 20"E	35.36'	18.90'

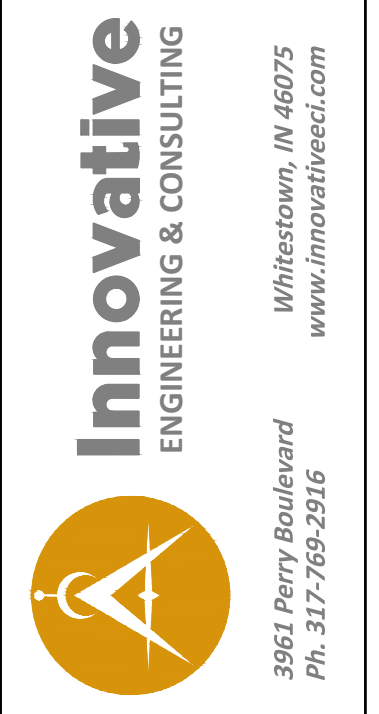

REVISIONS:

1	REVISED PER IAC COMMENTS - 8/28/23
---	------------------------------------

Prepared for:
Arbor Homes
 9225 Harrison Park Ct.
 Indianapolis, Indiana 46216

Thorntown Residential
 Westfall Place
 8401 West State Road 47, Thorntown, Indiana 46071
 PRIMARY PLAT

**PRELIMINARY
 PENDING
 AGENCY
 APPROVAL**

DATE: 08/30/23
 DRAWN BY: kwk
 ISSUED: CHECKED BY:
 JOB NUMBER: 22101
 SHEET # P104

LEGEND

- Existing Storm Sewer
- New Storm Sewer
- Existing Sanitary Sewer
- New Sanitary Sewer & Lateral
- Existing Contour
- Existing Elevation
- New Pavement Grade
- Denotes Approximate Pad Size
- Flow Arrow
- 8" WTR
- New Water Main
- New Fire Hydrant
- New Water Valve
- New Double Water Meter & Service Line
- New Single Water Meter & Service Line
- Existing Gas Main
- Existing Telephone
- Existing Water Main
- Existing Flowline
- Existing Overhead Utilities
- Existing Water Main
- Existing Fire Hydrant
- Existing Water Valve
- Utility & Drainage Esmt.
- Building Setback Line
- Drainage & Utility Esmt.
- Drainage Easement
- Regulated Drainage Easement
- Utility Easement
- Water Easement
- Landscape Easement
- Building Setback Line
- Water Quality Structure

NOTE:
SEE SHEET P108 FOR TYPICAL STREET SECTION
SEE SHEET P108 FOR TYPICAL POND SECTION

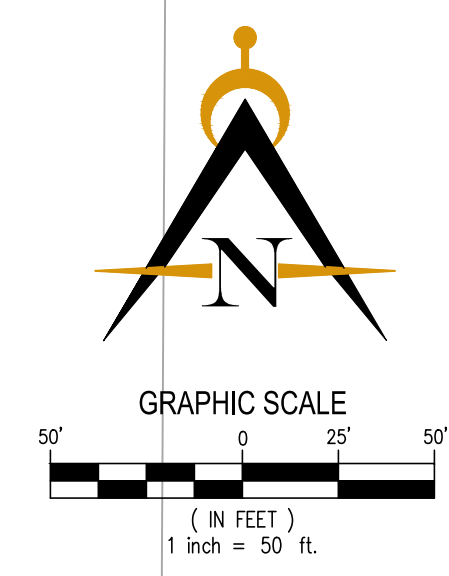
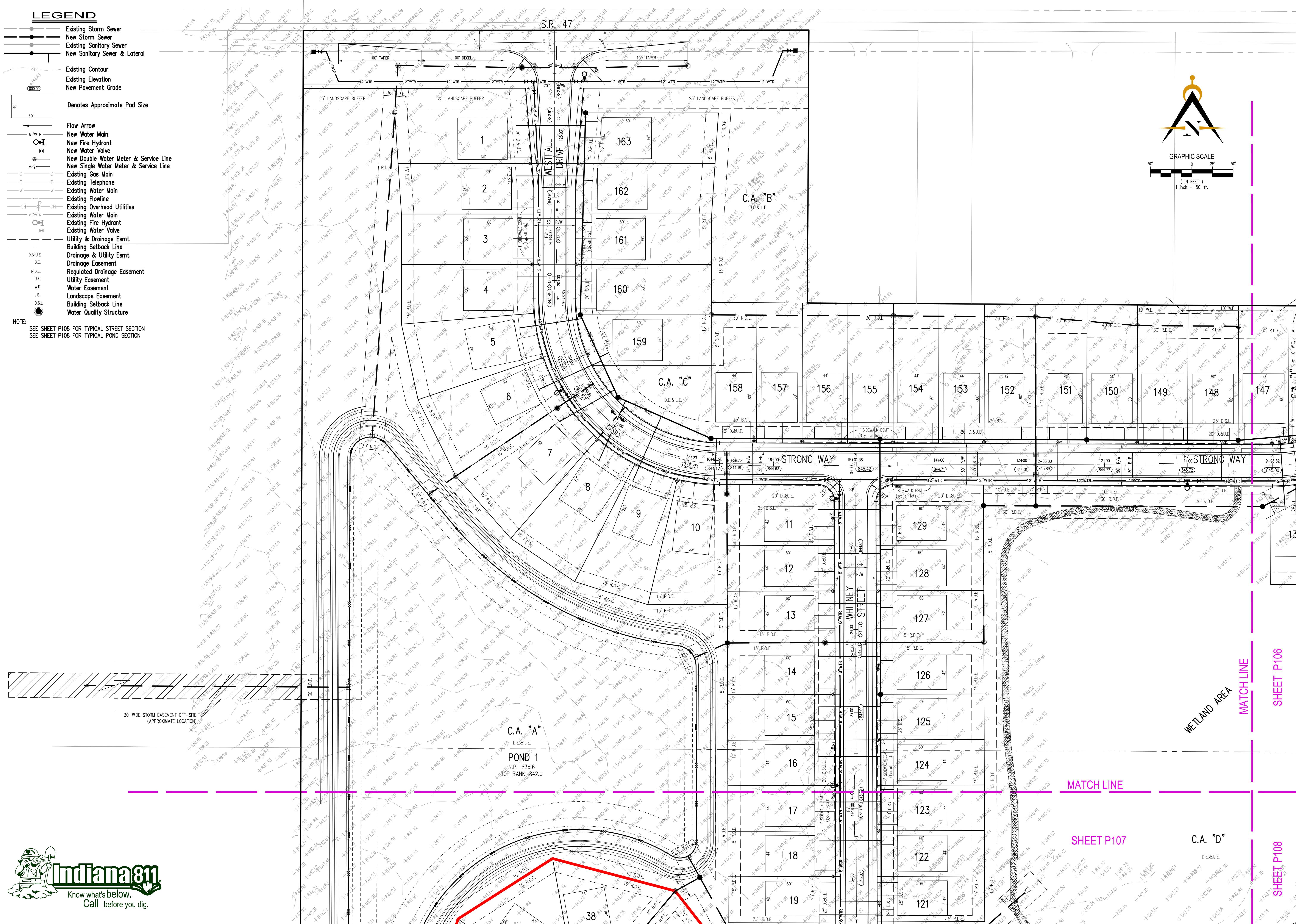

REVISIONS:
1) REVISED PER IAC COMMENTS - 8/28/23

Arbor Homes
9225 Harrison Park CT
Indianapolis, Indiana 46216

Thorntown Residential
Westfall Place
8401 West State Road 47, Thorntown, Indiana 46071
DEVELOPMENT PLAT

PRELIMINARY
PENDING
AGENCY
APPROVAL

DATE:	08/30/23	DRAWN BY:	kwk
ISSUED:		CHECKED BY:	
JOB NUMBER:	22101		
SHEET #	P105		



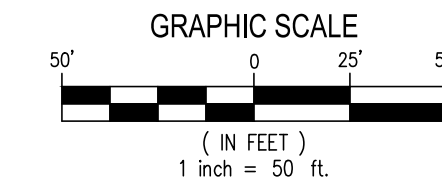
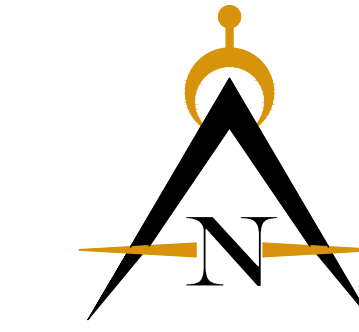

LEGEND

- Existing Storm Sewer
- New Storm Sewer
- Existing Sanitary Sewer
- New Sanitary Sewer & Lateral
- Existing Contour
- Existing Elevation
- New Pavement Grade
- Denotes Approximate Pad Size
- Flow Arrow
- New Water Main
- New Fire Hydrant
- New Water Valve
- New Double Water Meter & Service Line
- New Single Water Meter & Service Line
- Existing Gas Main
- Existing Telephone
- Existing Water Main
- Existing Flowline
- Existing Overhead Utilities
- Existing Water Main
- Existing Fire Hydrant
- Existing Water Valve
- Utility & Drainage Esmt.
- Building Setback Line
- Drainage & Utility Esmt.
- Drainage Easement
- Regulated Drainage Easement
- Utility Easement
- Water Easement
- Landscape Easement
- Building Setback Line
- Water Quality Structure

NOTE:
SEE SHEET P108 FOR TYPICAL STREET SECTION
SEE SHEET P108 FOR TYPICAL POND SECTION

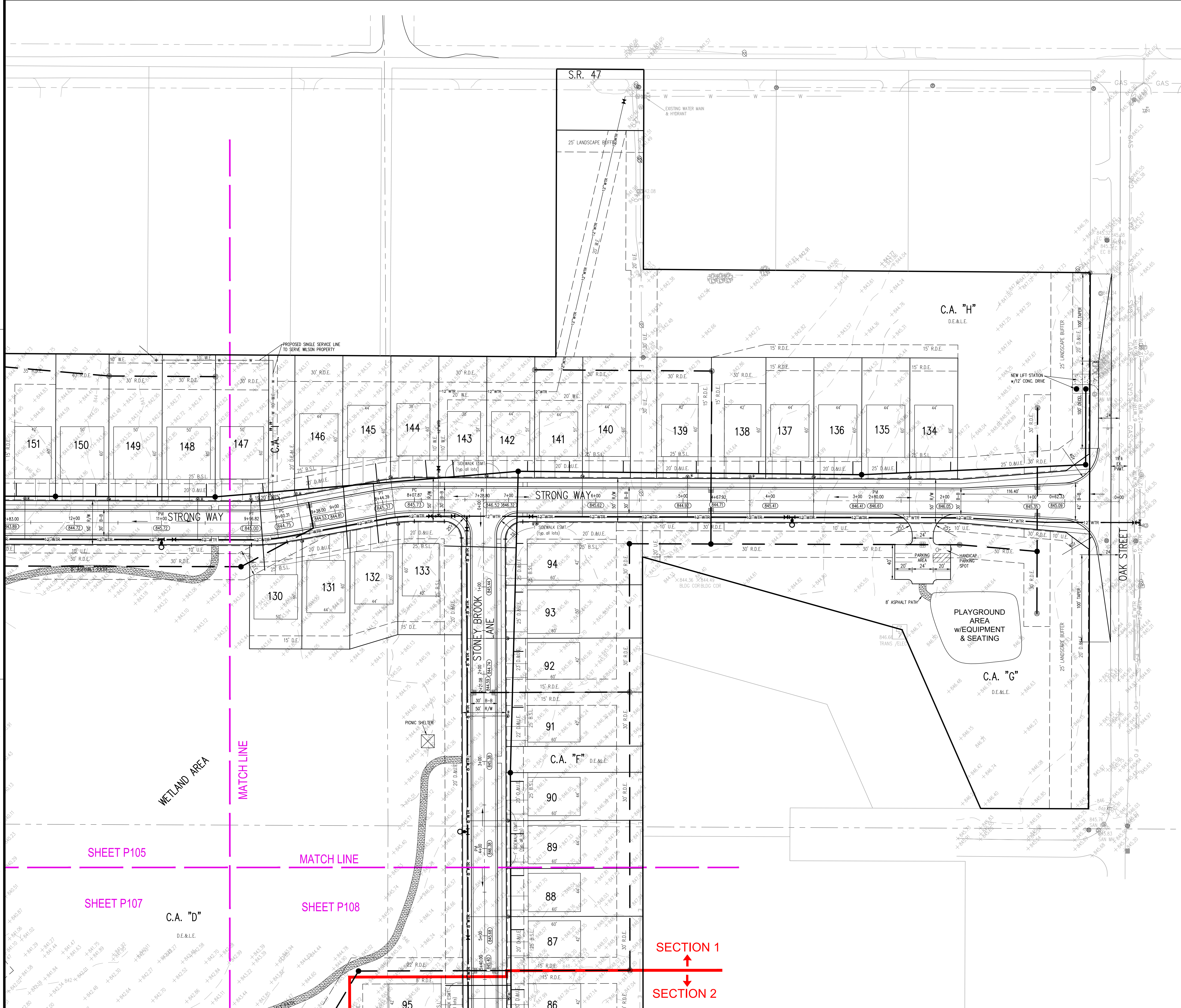

REVISIONS:
1) REVISED PER IAC COMMENTS - 8/28/23

Arbor Homes
9225 Harrison Park CT
Indianapolis, Indiana 46216

PREPARED FOR:
Thorntown Residential
Westfall Place
8401 West State Road 47, Thorntown, Indiana 46071
DEVELOPMENT PLAN

PRELIMINARY
PENDING
AGENCY
APPROVAL

DATE:	08/30/23	DRAWN BY:	kwk
ISSUED:		CHECKED BY:	
JOB NUMBER:	22101		
SHEET #	P106		

SECTION 1
↑
SECTION 2
↓

30' WIDE STORM EASEMENT OFF-SITE (APPROXIMATE LOCATION)



GRAPHIC SCALE
0 25 50
(IN FEET)
1 inch = 50 ft.

LEGEND

- Existing Storm Sewer
- New Storm Sewer
- Existing Sanitary Sewer
- New Sanitary Sewer & Lateral
- Existing Contour
- Existing Elevation
- New Pavement Grade
- Denotes Approximate Pad Size
- Flow Arrow
- New Water Main
- New Fire Hydrant
- New Water Valve
- New Double Water Meter & Service Line
- New Single Water Meter & Service Line
- Existing Gas Main
- Existing Telephone
- Existing Water Main
- Existing Flowline
- Existing Overhead Utilities
- Existing Water Main
- Existing Fire Hydrant
- Existing Water Valve
- Utility & Drainage Esmt.
- Building Setback Line
- Drainage & Utility Esmt.
- Drainage Easement
- Regulated Drainage Easement
- Utility Easement
- Water Easement
- Landscape Easement
- Building Setback Line
- Water Quality Structure

NOTE:
SEE SHEET P108 FOR TYPICAL STREET SECTION
SEE SHEET P108 FOR TYPICAL POND SECTION

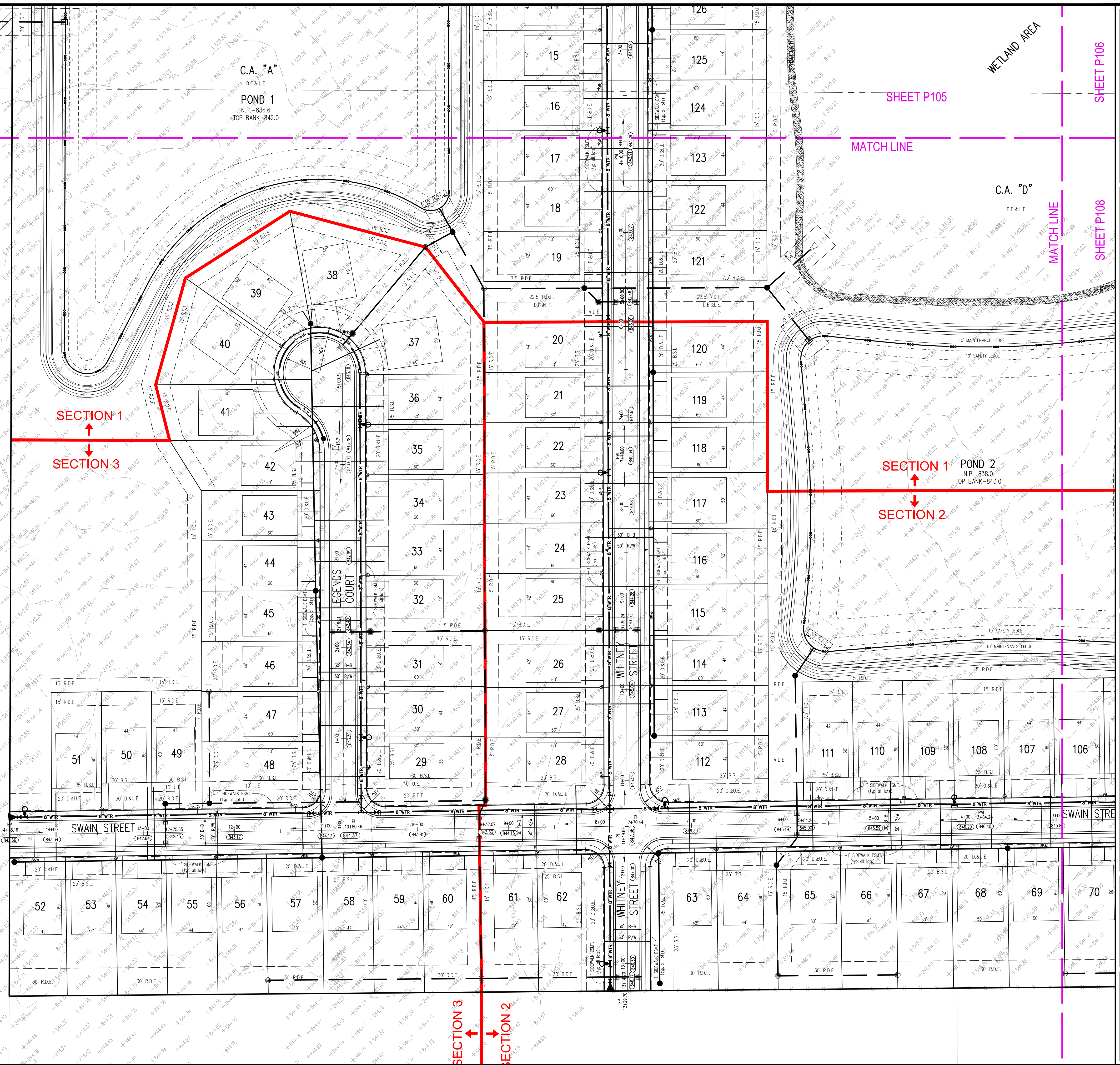

Innovative
ENGINEERING & CONSULTING

Whitestown, IN 46075
3961 Perry Boulevard
Ph: 317-769-2916
www.innovativeci.com

REVISIONS:
1) REVISED PER IAC COMMENTS - 8/28/23

PREPARED FOR:
Arbor Homes
9225 Harrison Park CT
Indianapolis, Indiana 46216

THORNTOWN RESIDENTIAL
Westfall Place
8401 West State Road 47, Thornton, Indiana 46071
DEVELOPMENT PLAN

**PRELIMINARY
PENDING
AGENCY
APPROVAL**

DATE:	08/30/23	DRAWN BY:	kwk
ISSUED:		CHECKED BY:	
JOB NUMBER:	22101		
SHEET #	P107		



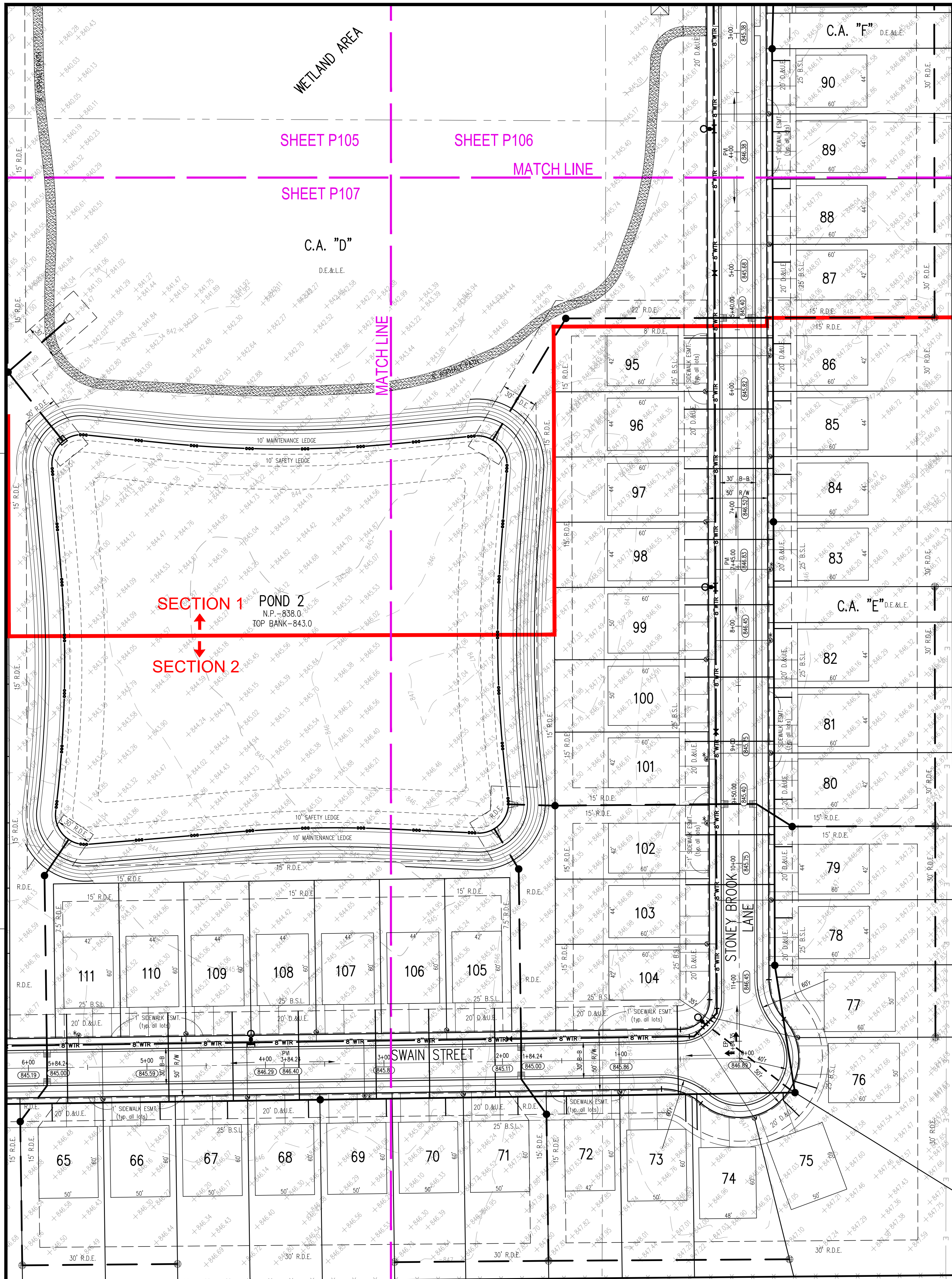

SECTION 1
↑
SECTION 2

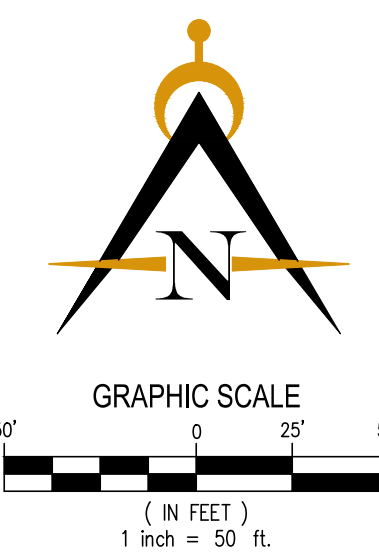

- LEGEND**
- Existing Storm Sewer
 - New Storm Sewer
 - Existing Sanitary Sewer
 - New Sanitary Sewer & Lateral
 - Existing Contour
 - Existing Elevation
 - New Pavement Grade
 - Denotes Approximate Pad Size
 - Flow Arrow
 - New Water Main
 - New Fire Hydrant
 - New Water Valve
 - New Double Water Meter & Service Line
 - New Single Water Meter & Service Line
 - Existing Gas Main
 - Existing Telephone
 - Existing Water Main
 - Existing Flowline
 - Existing Overhead Utilities
 - Existing Water Main
 - Existing Fire Hydrant
 - Existing Water Valve
 - Utility & Drainage Esmt.
 - Building Setback Line
 - Drainage & Utility Esmt.
 - Drainage Easement
 - Regulated Drainage Easement
 - Utility Easement
 - Water Easement
 - Landscape Easement
 - Building Setback Line
 - Water Quality Structure
- NOTE:
SEE SHEET P108 FOR TYPICAL STREET SECTION
SEE SHEET P108 FOR TYPICAL POND SECTION

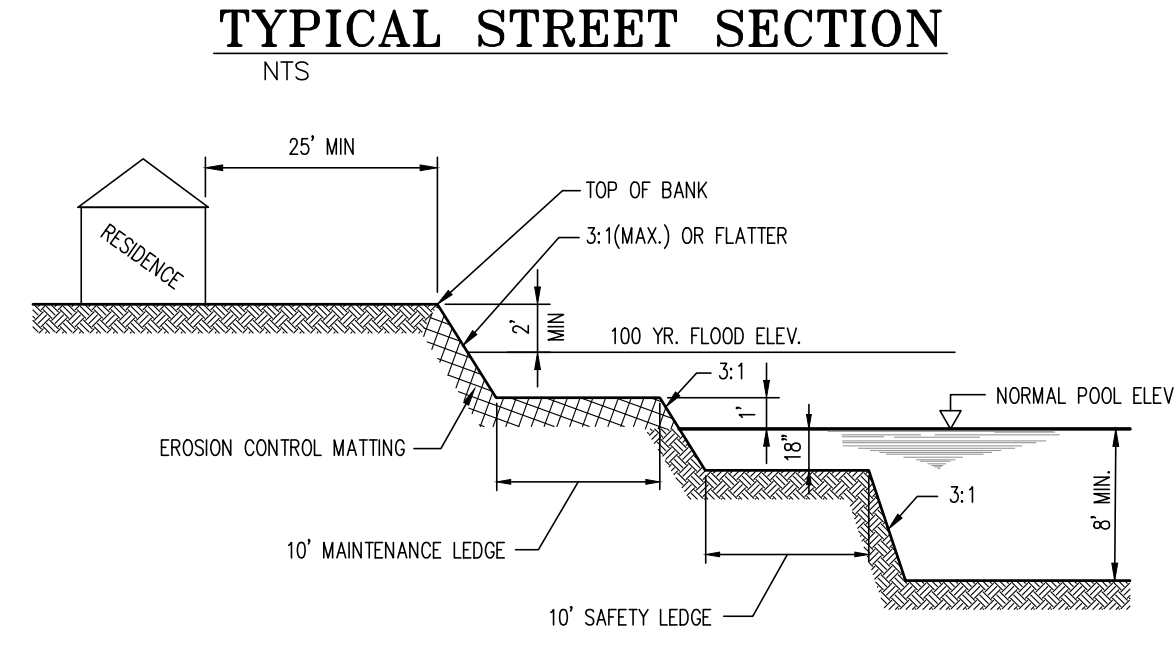
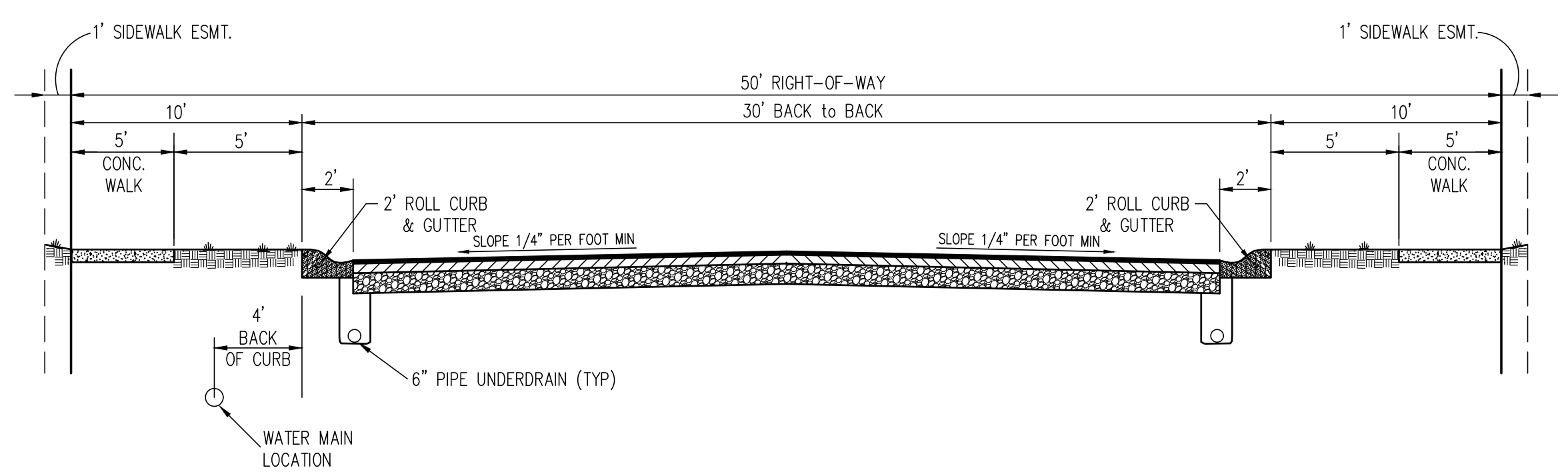

Innovative
ENGINEERING & CONSULTING
Whitestown, IN 46075
www.innovativeci.com
3961 Perry Boulevard
Ph: 317-669-2916

REVISIONS:
1. REVISED PER IAC COMMENTS - 8/28/23

Arbor Homes
9225 Harrison Park CT
Indianapolis, Indiana 46216

PREPARED FOR:
Thorntown Residential
Westfall Place
8401 West State Road 47, Thorntown, Indiana 46071
DEVELOPMENT PLAN

PRELIMINARY PENDING AGENCY APPROVAL

DATE: _____ DRAWN BY: kkw
08/30/23
ISSUED: _____ CHECKED BY: _____
JOB NUMBER: 22101
SHEET # P108